

# CE 201 CASE ERECTOR

## *Around the Clock Dependability*

- Variable Speed
- Heavy Duty Construction
- Allen Bradley Components
- Small Footprint
- Allen Bradley Micrologix PLC
- Mostly Mechanical Operation



A DOVER COMPANY

# CE 201 CASE ERECTOR

## Standard Features:

- Erects 8 to 30 Cases Per Minute (erects/bottom seals RSC, HSC, AFM & FOL style boxes)
- Automatic Jam Detection
- Pressurized Hot Melt System (an 18" case length can accommodate with the pressure sensitive tape option)
- Quick Changeover (5 minutes or less)
- Multiple Case Size Capability
- Double-40 Pre-Stretched Chain (with takeups, taper locks and QD sprockets)
- Scaled and Pointed Adjustments (for easy case setup)

## Available Options:

- U.L. Certification
- Tool-Less Changeover Available (only compression plate upgrade required)
- Steel Casters (convenient portability)
- Remote Start/Stop
- Power Infeed Conveyor (provides greater magazine capacity)

## BOX SPECIFICATIONS/OPERATING SEQUENCE

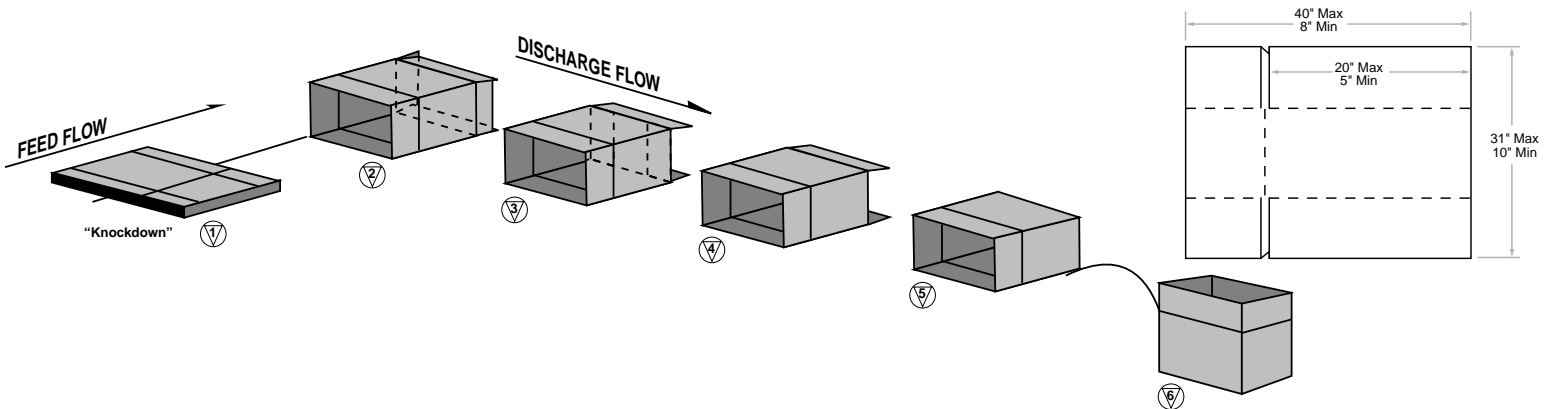

**Note: A five inch minimum case width is required.** The CE 201 is capable of the minimum and maximum shown. However, the full range, smallest to largest, cannot be realized on an individual machine.

## MACHINERY SPECIFICATIONS

### Many Models Available:

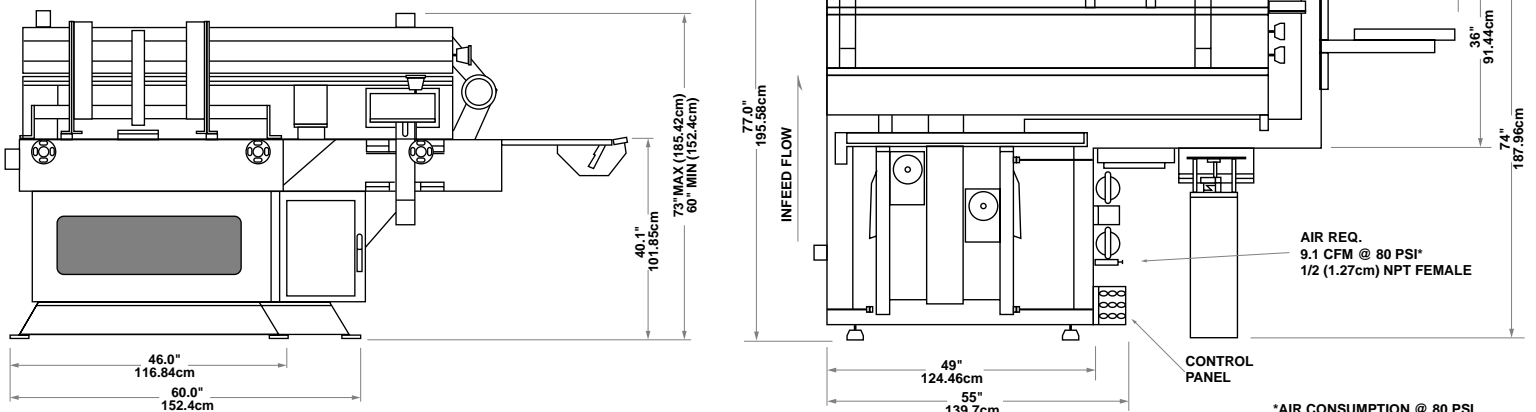

**\*AIR CONSUMPTION @ 80 PSI**  
 @ 15 CPM = 7.2 CFM  
 @ 20 CPM = 7.8 CFM  
 @ 25 CPM = 8.5 CFM  
 @ 30 CPM = 9.1 CFM



A DOVER COMPANY

1050 Miller Drive • Altamonte Springs, Florida 32701  
 Phone: (407) 260-0330 • Fax: (407) 260-7096 • Toll Free USA: (800) 214-1565  
 E-mail: info@swfcompanies.com • Web Site: www.swfcompanies.com

